

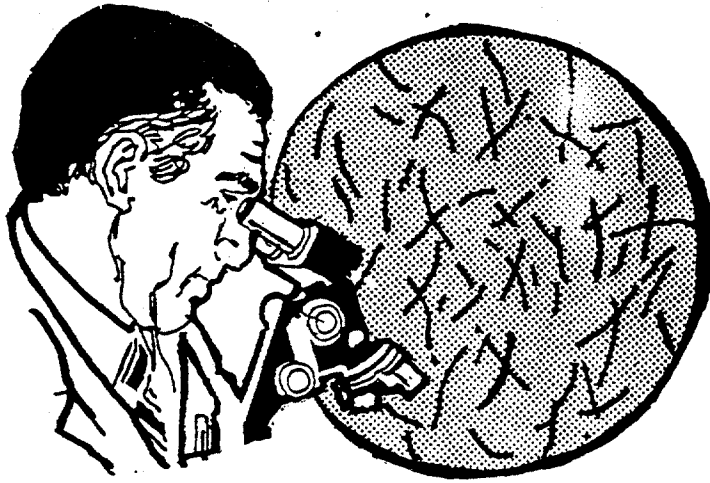

Measuring Airborne Asbestos Following An Abatement Action



**MEASURING AIRBORNE ASBESTOS FOLLOWING
AN ABATEMENT ACTION**

**Quality Assurance Division
Environmental Monitoring Systems Laboratory
Office of Research and Development
U.S. Environmental Protection Agency
Research Triangle Park, N.C. 27711**

and

**Exposure Evaluation Division
Office of Toxic Substances
Office of Pesticides and Toxic Substances
U.S. Environmental Protection Agency
Washington, D.C. 20460**

November 1985

ACKNOWLEDGMENTS

Many individuals contributed their time and effort to the preparation of this guidance document. The primary author is Dale L. Keyes of Environmental Sciences, Tucson, Arizona. Michael Beard (Office of Research and Development, Quality Assurance Division) and Joseph Breen (Office of Toxic Substances, Exposure Evaluation Division) served as Coauthors and Task Managers, and directed the report preparation process.

The material presented here is based in part on the results of a conference held in March 1984 and sponsored jointly by EPA and the National Bureau of Standards on post-abatement air monitoring for asbestos. The conference brought together government officials, research scientists, asbestos experts, abatement contractors, and others to share ideas and experiences. A draft of the guidance document incorporating the conference results together with other information was prepared and reviewed by several persons acting as official peer reviewers. The reviewers are:

Daniel Baxter, Science Applications, Inc.
Wolfgang Brandner, EPA Region VII
Lester Breslow, University of California
Jay Carter, National Institute of Occupational Safety and Health
Eric Chatfield, Ontario Research Foundation
William Ewing, Georgia Tech. Research Institute
Peter Frasca, Electron Microscope Service Lab
Richard Lee, U.S. Steel
Marshall Marcus, Marcus Associates
Anthony Natale, Duall Incorporated
Bertram Price, National Economic Research Associates
Tony Restaino, EPA Region V
John Small, National Bureau of Standards
Gerald Spencer, The Survey Group, Inc.
Eric Steel, National Bureau of Standards
Ian Stewart, McCrone Associates

Their effort in reviewing the first draft and in offering valuable comments is greatly appreciated.

Others providing valuable comments on various drafts of the document include Jean Chesson of Battelle Memorial Institute, William Nicholson of Mt. Sinai School of Medicine, Roger Wilmoth of EPA/ORD-Cincinnati, David Mayer of EPA/OPTS-Washington, and Ralph Sposato of EPA/ORD-RTP.

This report was prepared under subcontract to the Research Triangle Institute. Personnel there are also acknowledged for their assistance in the technical editing process.

The material contained within the document is guidance and does not constitute a Federal regulation.

TABLE OF CONTENTS

	<u>Page</u>
Acknowledgments	ii
Nontechnical Summary of the Guidance.	v
Chapter 1 - Introduction and Purpose.	1-1
Chapter 2 - Overview of Technical Guidance.	2-1
2.1 The Process for Releasing the Contractor.	2-1
2.2 Analyzing Air Samples for Asbestos.	2-1
2.3 Air Sampling Procedures	2-4
2.4 Air Testing Criteria for Determining Work Site Cleanliness After Abatement	2-5
2.5 Quality Assurance Practices	2-6
Chapter 3 - Sample Analysis	3-1
3.1 The Asbestos Measurement Problem.	3-1
3.2 Analysis by Phase Contrast Microscopy (PCM)	3-3
3.3 Analysis by Transmission Electron Microscopy (TEM).	3-3
3.4 Analysis by Scanning Electron Microscopy (SEM).	3-5
3.5 Comparison of the Three Methods for Post-Abatement Air Testing	3-7
Chapter 4 - Air Sampling Procedures	4-1
4.1 Sampling Equipment.	4-1
4.1.1 Filter Media	4-1
4.1.2 Filter Cassettes	4-1
4.1.4 Flow-Controlled Pumps and Orifices	4-2
4.2 Sampling Procedures	4-2
4.2.1 Checking Filter Assemblies	4-2
4.2.2 Measuring Airflow.	4-2
4.2.3 Determining Sampling Times and Volumes	4-5
4.2.4 Field Operations	4-6
4.3 Sampling Strategy	4-6
Chapter 5 - Air Testing Criteria for Determining Work-Site Cleanliness After Abatement	5-1
5.1 The Rationale for the Recommended Release Criteria.	5-1
5.2 Statistical Considerations for Using Release Criteria.	5-3

TABLE OF CONTENTS (con.)

	<u>Page</u>
5.3 TEM Release Criterion	5-4
5.3.1 Sampling Volume and Time	5-4
5.3.2 The Number and Location of Samplers.	5-4
5.3.3 Comparing Measured Levels of Airborne Asbestos	5-8
5.3.4 Recommended Actions if the Work Site Fails	5-8
5.4 PCM Release Criterion	5-9
5.4.1 Sampling Volume and Time	5-9
5.4.2 The Number and Location of Samplers.	5-9
5.4.3 Comparing Measured Levels of Asbestos to the Lowest Quantifiable Level.	5-9
5.4.4 Recommended Actions if the Work Site Fails	5-9
5.5 Example Applications of the Two Release Criteria.	5-9
5.5.1 PCM Example.	5-11
5.5.2 TEM Example.	5-11
Chapter 6 - Quality Assurance Practices	6-1
References.	R-1
Appendix A - A Random Number Procedure for Selecting a Representative Work-site Sample.	A-1

NONTECHNICAL SUMMARY OF THE GUIDANCE

One of the most critical points in an asbestos abatement project is knowing when the work has been completed, the contractor can be released, and the building can be reoccupied. This decision should be based on two factors: (1) satisfactory performance of the abatement work, and (2) thorough cleaning of the work site. As outlined below, these factors should be evaluated by visually inspecting the work site, and by measuring the level of airborne asbestos there. The evaluation should be conducted by the asbestos program manager or the technical advisor assigned to monitor the abatement work.

Visual Inspection

- Once the contractor has completed the abatement work but before any containment barriers have been dismantled, the project monitor should thoroughly inspect the work site for incomplete abatement and for evidence of dust and debris.
- Additional abatement and/or work-site cleaning is needed if the work site fails the visual inspection.

Air Testing

- Air testing should be conducted after the interior plastic barriers have been removed but before the final barriers separating the work site from the rest of the building have been taken down.
- Three methods for measuring airborne asbestos are available: phase contrast microscopy (PCM), scanning electron microscopy (SEM), and transmission electron microscopy (TEM). TEM is the best method for measuring the types of fibers expected to be present at abatement work sites, but PCM is more available and practical in many localities. SEM lacks a standard analytical protocol, laboratory testing programs, and standard reference materials for judging the accuracy of SEM analyses.
- Regardless of which method is used, air samples should be taken "aggressively". This means, air blowers should be used to dislodge fibers from surfaces, and fans should be used to keep them suspended.
- At least five samples should be taken inside the work site, and, if TEM is used for sample analysis, another five outside the work site should be collected. Specified sampling equipment, flow rates, and sampling volumes should be used.

- One of two alternative criteria should be used to determine if the work site has been adequately cleaned:
 - For TEM, the average level of airborne asbestos for the samples inside the work site should be no higher than the average for the samples outside the work site.
 - For PCM, the level of airborne fibers for each of the samples inside the work site should be less than PCM's limit of reliable quantification (0.01 or fewer fibers per cubic centimeter if the minimum recommended volume of air is collected).
- If the work site fails the air test, it should be recleaned and retested.

The following chapters discuss various technical issues regarding the air test. Specifications are provided for air sampling and detailed guidelines are presented for using either TEM or PCM to analyze the samples. The information is designed for asbestos program managers and technical program advisors.

CHAPTER 1

INTRODUCTION AND PURPOSE

Asbestos-containing material (ACM) in buildings is a potential concern for a growing number of building owners. EPA estimates that 31,000 schools and 733,000 public and commercial buildings contain friable (easily crumbled) asbestos (USEPA, 1984a and 1984b). ACM which is damaged, disturbed, or deteriorated will release asbestos fibers and possibly create a health hazard for building occupants.

Many building owners have undertaken or are considering some form of abatement (removal, enclosure, encapsulation, or repair of the ACM). Although EPA's "Friable Asbestos-Containing Materials in Schools; Identification and Notification Rule" (40 CFR Part 763) does not require that schools take corrective action when asbestos is detected, the parent and employee notification requirements of the Rule have stimulated the majority of school districts to do so (USEPA, 1984a). Owners of many other types of buildings also have developed asbestos control programs.

EPA has published several guidance documents to assist building owners in understanding the relevant technical issues, determining if asbestos is present, planning a control program if necessary, and choosing a course of action. The latest update of the EPA guidance is: "Guidance for Controlling Asbestos-Containing Materials in Buildings, 1985 Edition," June 1985 (USEPA, 1985).

Once ACM has been detected in a building and the need for abatement determined, conducting the abatement action in a safe and thorough manner is crucial. Releasing the abatement contractor is the final step in the abatement process (although a continuing operations and maintenance program may be necessary until the building is demolished*). This guidance document addresses the question of what criteria can be used to judge when the contractor can be released. It supplements and extends previous EPA guidance by recommending specific procedures for using air monitoring in making these judgments. The material is presented in technical language, and is thus directed to asbestos program managers, technical program advisors, and others involved with asbestos abatement work and air testing.

The guidance offered here is based in part on the results of a two-day conference sponsored jointly by EPA and the National Bureau of Standards (NBS) held in March 1984. The evidence presented and the conclusions reached by the conference participants have been examined in light of other information reported in the open literature and government studies. In this sense, the guidance document reflects the interpretation and judgment of EPA in addition to the collective experience and knowledge of the conference participants.

* See USEPA 1985 for a description of special O&M programs for buildings with ACM.

EPA will continue to gather data and conduct research on the subject of air monitoring for asbestos following an abatement project. To this end, the experience of asbestos program managers, asbestos consultants, abatement contractors, and others working on asbestos control projects could prove to be highly informative. Any information on measurements of airborne asbestos in buildings with ACM made by phase contrast microscopy, scanning electron microscopy, or transmission electron microscopy may be forwarded to:

U.S. Environmental Protection Agency
Environmental Monitoring Systems Laboratory
Quality Assurance Division (MD-77)
Re: Asbestos Monitoring Data
Research Triangle Park, N.C. 27711

EPA is especially interested in measurements of airborne asbestos made inside the work site during ACM abatement activities, and, once the abatement is completed, after each work-site cleaning by the abatement contractor prior to his release. It would be appreciated if data forwarded to EPA include basic information such as asbestos fiber concentration, sample volume, analytical procedure, number and type of asbestos fibers counted, sample preparation technique (direct or indirect).

CHAPTER 2

OVERVIEW OF THE TECHNICAL GUIDANCE

The guidance offered here addresses the question of how to determine when an asbestos abatement work site has been sufficiently cleaned. It is set within the larger framework of determining when the abatement work is completed and when to release the contractor, but it focusses specifically on the use of air sampling and analysis to determine work-site cleanliness. Procedures for conducting post-abatement air sampling are specified and methods for measuring airborne asbestos and interpreting the results are recommended.

Following are summaries of each major topic in the guidance document, preceded by a brief discussion of the process for releasing the abatement contractor. The major topics include analyzing air samples for asbestos, air sampling procedures, criteria for determining work-site cleanliness, and quality assurance practices.

2.1 THE PROCESS FOR RELEASING THE CONTRACTOR

The most recent EPA guidance on controlling ACM in buildings (USEPA 1985) describes a two-part process for determining when an abatement project is complete and the contractor can be released. As illustrated in Figure 2-1, the two steps are: (1) a visual test to determine if the ACM has been properly abated and if the work site is free of debris and dust, and (2) an air test to determine if residual asbestos fibers generated during abatement have been reduced below a predetermined level, that is, to determine if the air-test release criterion has been met. The asbestos program manager or the person appointed to monitor the abatement work should be responsible for conducting the visual test and overseeing the air test.

The visual test is designed, first, to spot any incomplete abatement work. If the ACM is surfacing material, abatement could mean removal, encapsulation, or enclosure (USEPA, 1985). If the ACM is pipe or boiler insulation, abatement could mean removal, patching, or replacement of the protective jacket (USEPA, 1985). In any case, the quality and thoroughness of the work is reviewed. Deficiencies should be corrected before proceeding with the next phase of the inspection.

The second role of the visual inspection is to detect obvious signs of inadequate work-site cleaning. The abatement contractor should clean all plastic barriers at the work site using wet cleaning or HEPA vacuuming techniques (USEPA, 1985). The inspector should use damp cloths and a flashlight to check for debris and dust (USEPA, 1985).

The air test is designed to detect asbestos fibers which were not removed by the cleaning procedures. Before the test is conducted, all plastic barriers are removed except those covering vents, windows, doors, and all entries to the work site. This will allow any fibers trapped between the plastic and floors, walls, and/or ceilings to become

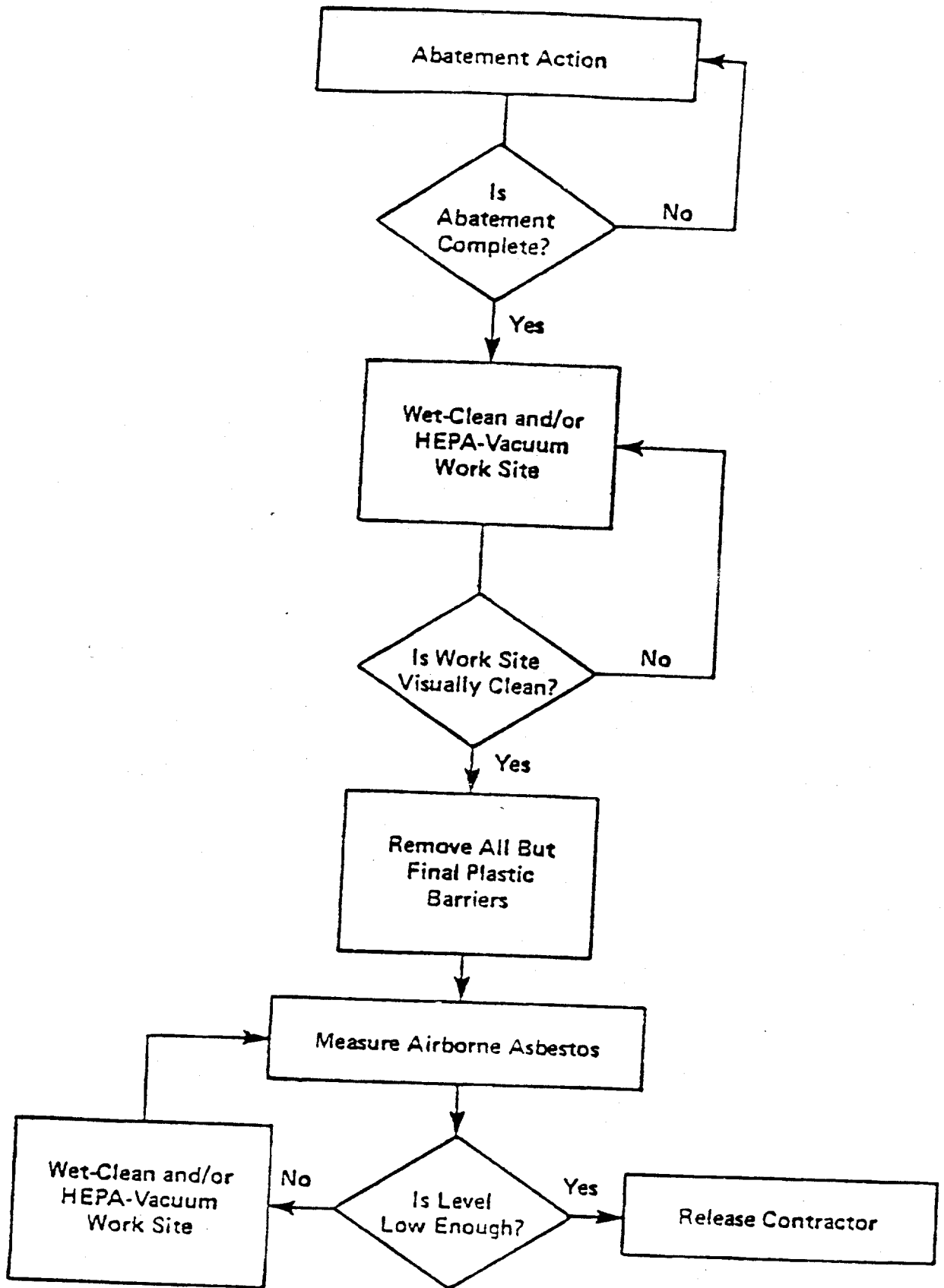

Figure 2-1. The process for releasing the contractor.

airborne before testing is begun. If the air test criterion is met, the contractor is released. Otherwise, the work site must be thoroughly recleaned.

2.2 ANALYZING AIR SAMPLES FOR ASBESTOS

Three microscopic methods are currently being used to analyze airborne asbestos: phase contrast microscopy (PCM), scanning electron microscopy (SEM), and transmission electron microscopy (TEM). Because asbestos fibers are small (especially those found in buildings with ACM) and difficult to distinguish from other types of fibers, the detection and accurate identification of asbestos requires sophisticated methods of analysis.

TEM is the best method for measuring airborne asbestos. It can detect the very thin fibers (typically down to 0.0025 μm diameter) found in buildings with ACM and in the ambient atmosphere, and it has the capability of identifying asbestos unambiguously. In addition, a standard protocol for TEM analysis has been developed by EPA, and standard reference materials for instrument calibration and accuracy checks are available from the National Bureau of Standards (NBS). PCM is less sensitive to thin fibers and less specific for asbestos. When used according to the National Institute of Occupational Safety and Health (NIOSH) protocols, PCM cannot detect fibers smaller than 0.25 μm in diameter, and cannot distinguish asbestos from other types of fibers. As a result, PCM results can only be considered an index of airborne asbestos levels. However, the method has a well-developed protocol, and NIOSH operates a testing program for PCM laboratories. SEM is somewhat more sensitive and specific than PCM but less so than TEM. Significantly, no standard protocol nor NBS standard reference materials are available for SEM. As a result, SEM analyses are currently of unknown reliability. Anyone using SEM for measuring airborne asbestos should require the analytical laboratory to document the relationship between SEM and either PCM or TEM results.

With respect to method availability, cost, and "turnaround time" (i.e., the time between submission of samples and receipt of results), PCM is superior on all accounts. It is by far the most available and (by a factor of 2-10 depending on the level of analysis) the least expensive. The turnaround time is usually less than 6 hours compared with 6-24 hours for SEM and 2-7 days for TEM. Note, however, that availability, cost, and time factors may change significantly in the future.

RECOMMENDATIONS

- Either TEM or PCM should be used to analyze air samples for asbestos fibers. TEM is the method of choice but PCM is more practical. Without standard protocols and reference materials, SEM results are difficult to evaluate.

- Use TEM according to the updated EPA protocol (direct sample preparation, if possible; Level I analysis may be sufficient), and PCM according to the NIOSH P&CAM 239 (or, alternatively, NIOSH 7400) protocol.

2.3 AIR SAMPLING PROCEDURES

Air sampling is conducted by drawing air through a filter at a known rate. Typically, flow-controlled pumps and either cellulose ester or polycarbonate filters (depending on the method of sample analysis) are used. Specific sampling procedures should be followed in order to assure reliability of the results.

In addition to the use of appropriate sampling equipment, the sampling plan must be carefully designed to account for normal variability in asbestos levels from location-to-location and over time. One of the most important factors which influence the degree of variability in air measurements is the pattern of air movement. Under conditions of limited movement, many fibers will settle out of the air. Measurements of airborne asbestos under these conditions are likely to be lower than if all the fibers were suspended. Artificial agitation of the air in a building is one way to keep the fibers suspended.

RECOMMENDATIONS

- Use constant-flow sampling pumps and the following filters:
 - For PCM analysis: cellulose ester filters with 0.8-1.2 μm pore size.
 - For TEM analysis: polycarbonate filters with 0.4 μm pore size.
- Use the specified procedures for testing and operating sampling equipment.
- Sample at a flow rate of between 2 and 12 liters per minute (L/min).
- Sample aggressively:
 - Use forced-air equipment such as a leaf blower to initially dislodge fibers from surfaces.
 - Use fans as specified to keep fibers suspended during sampling.

2.4 AIR TESTING CRITERIA FOR DETERMINING WORK-SITE CLEANLINESS AFTER ABATEMENT

Regardless of which method is used to analyze air samples for asbestos, the results of the analyses can only be used for releasing a contractor if a criterion is available against which the results can be compared. In other words, how low do the measured asbestos levels have to be in order for the work site to be declared sufficiently clean?

Since an abatement contractor could not be expected to reduce asbestos levels below those in the air entering the work site, the level of airborne asbestos in the ambient air (or in the make-up air if negative pressure ventilation is used at the work site [USEPA, 1985]) appears to be a reasonable reference. This is the case for TEM. PCM, however, is not sufficiently sensitive to thin fibers nor specific for asbestos to reliably measure asbestos outside the abatement work site. A criterion based on the limit of reliable quantification of the analytical method is more appropriate for PCM.

The recommended number of TEM samples and the minimum sampling volume needed to compare measured asbestos levels at the work site against the reference level should take into account the expected variability in TEM measurements, how low the reference asbestos level is likely to be, and the detection limit of the TEM method. Sampling requirements for PCM should be at least as rigorous as those for TEM, considering PCM's low sensitivity to thin fibers and lack of specificity for asbestos.

RECOMMENDATIONS

- If TEM is used:
 - Collect five samples within and five outside the work site, each of at least 3000 liters. (Use blank filters and duplicate samples for reliability checks as specified.)
 - Analyze the samples and express the results as f/cc (or ng/m³ if an indirect sample preparation is necessary).
 - Compare the averages of the inside and outside levels using the statistical t-test.
 - Release the contractor if the inside level is not statistically higher than the outside level; otherwise, have the entire work site recleaned and retested.

- If PCM is used:
 - Collect at least five samples per work site or one per room, whichever is greater, each of at least 3,000 liters. (Use blank filter and duplicate samples for reliability checks as specified.)
 - Analyze the samples.
 - Release the contractor if none of the samples are above the PCM limit of reliable quantification (0.01 f/cc if 3,000 liters are sampled); otherwise, have the entire work site recleaned and retested.

2.5 QUALITY ASSURANCE PRACTICES

Measuring airborne asbestos is a sophisticated and exacting process. Errors may be introduced at any one of the many data collection and analysis steps. To guard against this possibility and to assure reliable results, a formal quality assurance program should be adopted.

RECOMMENDATIONS

- Be sure that all persons and organizations involved in sampling and analysis are trained and/or experienced. Check references and documented levels of performance.
- Use field and laboratory blanks to check for fiber contamination, coded sample labels to avoid analyst bias, duplicate analyses to confirm analytical precision, and a second laboratory to spot-check the accuracy of results. Be sure that all equipment setup, operation, and calibration procedures are followed.
- Assign responsibility for security of the samples to specific persons at each stage of the analysis. Document each step in the passage of the sample from the field to the laboratory to the building owner.
- Check and document laboratory results. The building owner should retain all test results and records documenting the testing process. Filters should also be saved in case additional analyses need to be conducted in the future.

CHAPTER 3

SAMPLE ANALYSIS

Three options for analyzing air samples for asbestos were summarized in Chapter 2: PCM, SEM, and TEM. The recommended option is TEM based on its superior technical capabilities. However, PCM is a more practical alternative in many localities. SEM needs development of a standardized protocol and standard reference materials. The rationale for these guidelines is presented more fully in this chapter.

3.1 THE ASBESTOS MEASUREMENT PROBLEM

Analyzing a sample of air for asbestos is a technically challenging problem. Asbestos fibers are extremely small and may number several million for an average size room when friable ACM is present (Chesson, et al., 1985a). Thus, only a small fraction of the asbestos fiber population can be observed and counted. Significant errors can be introduced when the results of the sample analysis are extrapolated to the entire room. Furthermore, fibers of asbestos may closely resemble those of hair, cloth, fibrous glass, paper, and other nonasbestos materials. As a result, identifying and counting asbestos fibers requires sophisticated instruments, highly trained technicians, and rigorous quality assurance practices.

3.2 ANALYSIS BY PHASE CONTRAST MICROSCOPY (PCM)

The Occupational Safety and Health Administration (OSHA) has adopted a standard protocol for measuring exposure to airborne asbestos in the industrial workplace. This protocol, P&CAM 239, (Leidel et al., 1979) was developed by the National Institute of Occupational Safety and Health (NIOSH) and specifies PCM as the measurement method*. The NIOSH protocol further specifies that only fibers with a 3:1 aspect ratio and longer than 5 micrometers (μm) in length should be counted.

The NIOSH protocol involves collecting airborne fibers on a standard 37-millimeter (mm), 0.8- μm pore-size cellulose ester filter. A pie-shaped section of filter is then analyzed by dissolving the filter and counting the fibers with PCM at 400X magnification. Phase contrast increases the light contrast between the object and the background, thus enhancing the microscopist's ability to see fibers. Normally, 100

* NIOSH has published a revised protocol--NIOSH 7400 (NIOSH, 1984). OSHA is now reviewing this revised protocol, but has not adopted it yet.

microscopic fields or 100 fibers are counted, whichever occurs first.*

PCM, as employed in the NIOSH protocols, has two serious limitations for measuring airborne asbestos. First, PCM can not distinguish asbestos from nonasbestos fibers; all elongated particles with the required length and aspect ratio are counted. PCM-measured fibers thus can only serve as an index of asbestos fibers. Second, only particles larger than about 0.25 μm in diameter can be detected owing to inherent limits of resolution of PCM, and only particles longer than 5 μm are counted due to the counting protocol.

These are not serious limitations for the use of PCM in asbestos workplace settings where asbestos fibers are a significant fraction of all airborne fibers. Moreover, variation over time in levels of PCM-measured fibers and asbestos fibers appears to be correlated in the asbestos workplace; that is, the higher the level of PCM fibers, the higher the level of asbestos. These relationships are borne out by studies of the health of workers in asbestos industries in which levels of PCM-measured fibers serve as the index of exposure to asbestos (NRC, 1984).

With one exception, conditions in buildings with friable ACM are believed to be quite different. Although evidence is limited, asbestos fibers appear to be smaller in size (fewer fiber bundles) and a smaller fraction of all airborne fibers than those in asbestos industry settings (Chatfield, 1983). A recent study of schools with friable ACM found very low correlations of fiber levels measured by PCM compared with asbestos levels measured by SEM and TEM (Chesson et al., 1985a).

The exception to this general rule may be fiber levels generated during asbestos abatement activities. Levels of both PCM and asbestos fibers are likely to be elevated during abatement, especially during removal of friable ACM. In this sense, the abatement work site may approximate conditions in the asbestos industry workplace. Thus, OSHA requires measurements of airborne fibers by PCM during abatement projects as an indication of asbestos exposure.

The justification for using PCM-measured fibers as the basis for determining when the abatement worksite has been sufficiently cleaned, that is, as the release criterion, follows from the above argument. If levels of both PCM and asbestos fibers are elevated during abatement activities, then removing PCM fibers should remove asbestos fibers as well. In other words, work-site cleaning practices which reduce levels of airborne cellulose, hair, and other large fibers detected by PCM should likewise reduce levels of residual asbestos fibers. However, this rationale rests on logical deduction; no simultaneous measurements of PCM and SEM or TEM levels during an abatement action and following work site cleaning operations have been made to test the rationale.

* A minimum of 10 fibers needs to be counted for reliable quantification (Leidel et al., 1979). Counting more than 100 fibers or 100 fields would be unnecessarily time-consuming and would add little to the reliability of the results.

Of the three methods for measuring airborne asbestos, PCM is the least expensive (about \$25-\$50 per sample) and the most readily available. In addition, results of PCM analysis can usually be communicated to the building owner in less than 6 hours. Finally, the NIOSH protocol has been extensively tested and an active laboratory evaluation program, the Proficiency Analytical Testing (PAT) Program, is maintained by NIOSH.*

3.3 ANALYSIS BY TRANSMISSION ELECTRON MICROSCOPY (TEM)

The limit of a microscope's ability to detect objects is related to the wavelength of the source of "illumination". Since electrons have a much shorter wavelength than does light, the electron microscope is inherently superior to the optical microscope for detecting small fibers typical of asbestos fiber populations found in buildings with ACM.

Of the two types of electron microscopy used for measuring airborne asbestos, TEM is considered the method of choice (Chatfield, 1983; Steel and Small, 1985). Following the EPA provisional methodology for TEM analysis (Samudra et al., 1978), fibers are collected on a 0.4 μm pore size polycarbonate filter (or on a 0.45 μm pore size cellulose ester filter if significant levels of contaminating organic materials are present in the air). Sample preparation involves either (1) direct transfer of collected fibers from the polycarbonate filter to an electron microscope (EM) grid after the filter is first carbon-coated, or (2) an indirect transfer whereby a section of the cellulose ester filter is ashed, the asbestos fibers are sonicated in water and refiltered on a polycarbonate filter, and then carbon-coated and transferred to the EM grid.** Direct transfer is preferred since it does not cause fiber breakage. The mounted fibers are then examined at 20,000X magnification, identified as asbestos, measured, and counted. The mass of each fiber may also be estimated if estimates of mass concentration are desired. No more than 100 fibers or 10 grid openings need to be observed.

TEM is the method of choice for analyzing asbestos based on its sensitivity to the smallest fibers and on its specificity for asbestos. Since the sample of fibers is mounted on an extremely thin substrate on the EM grid, electrons can pass through the substrate, be diffracted by the fibers and other materials, and be refocused into an image on a fluorescent screen, all without substantial back-scatter of electrons. This allows high electron beam voltage (approximately 100 kilovolts) and high magnification of the specimen (up to 100,000X). Extremely thin asbestos fibers (typically 0.0025 μm in diameter) can be detected.

* The results of the PAT program should be used in selecting a laboratory for PCM analysis. Call (513) 841-4357 for a copy of the latest evaluation results.

** A direct transfer technique for cellulose ester filters has also been reported (Burdett and Rood, 1983).

TEM can be used to indicate the likely presence of asbestos in a population of fibers based on fiber shape and configuration alone. However, in order to confirm the identity of the fibers, chemical and crystal analysis of individual fibers is needed. The relevant analytical techniques are known as energy dispersive X-ray spectrometry (EDXA or EDS) and selective area electron diffraction (SAED). In EDXA, X-rays emitted from interactions between the electron beam and the fibers are analyzed, and in SAED, the electron diffraction patterns created by the same interactions are analyzed.

A TEM instrument outfitted with EDXA and SAED capabilities is sometimes called an analytical electron microscope. The high electron beam voltage characteristic of TEM combined with the thinness of the fiber substrate on the EM grid allows EDXA and SAED to be performed on single fibers. Although each fiber observed is not always subjected to EDXA and SAED analysis, the preliminary identification of asbestos-like fibers combined with chemical and crystal analysis of a representative subset of fibers allows the fiber population to be characterized with a high level of confidence. In addition, SAED can be performed visually (by quickly observing the diffraction pattern on the fluorescent screen) or quantitatively (by photographing the diffraction pattern at an angle and measuring the photograph). The latter is a definitive means of identifying asbestos.

The extreme sensitivity of TEM does make the task of detecting and assessing thick fibers (larger than about 1.0 μm) and fiber clusters and bundles more difficult. Because thin fibers greatly outnumber thick ones in air samples from buildings with friable ACM (Chatfield, 1983; Chesson et al., 1985), counting fibers on the EM grid may stop before any large fibers are observed. Although the failure to observe thick fibers will not significantly affect fiber counts, it will bias downward the estimation of fiber mass, since a single large fiber may equal the mass of several thousand small fibers. Likewise, fiber clusters and bundles may be infrequently found. However, the clusters and bundles are so difficult to accurately measure and are so large in mass compared to individual fibers that the revised EPA protocol specifies that the presence of clusters and bundles be noted but not included in fiber counts or estimates of mass concentrations (Yamate, 1984).

Scanning transmission electron microscopy (STEM) has been employed by some laboratories to aid in identifying large fibers. STEM is performed by scanning the field of view at a lower magnification (typically 1000X). Not all transmission electron microscopes have scanning capabilities.

Given the complexity and sophistication of the TEM analysis for asbestos, the need for highly skilled microscopists and detailed protocols is apparent. Early attempts to compare analyses of the same air sample by several laboratories revealed that the analytical results varied by several orders of magnitude (USEPA, 1977a). Since then, efforts to standardize sample preparation and analysis protocols and to develop strict quality assurance practices have greatly improved the reliability of asbestos analyses by TEM. A recent study by the NBS revealed that TEM microscopists in the study had a greater than 90

percent chance of identifying chrysotile fibers longer than 1 μm (Steel and Small, 1985). However, the authors also noted that instrument characteristics (especially, the mechanical stage, image quality, and electron diffraction capabilities) can be a significant source of error. On the other hand, the availability of NBS standard reference materials for asbestos (Small et al., 1985) and the use of special counting procedures like the one described by the NBS authors (Steel and Small, 1985) can be used to evaluate the reliability and accuracy of TEM results.

The major disadvantages to using TEM for post-abatement clearance monitoring are the cost and time for analysis. Partly because few laboratories currently offer TEM services, costs for analysis may be \$500 or higher per sample, and the time until results are received may be several days. To reduce the cost and turnaround time, EPA has proposed three levels of TEM analysis (Yamate, 1984):

- Level I - Identification of asbestos fibers is based on fiber morphology and the observed SAED pattern on the fluorescent screen.
- Level II - Analysis of the chemical composition of each fiber by EDXA is added to the Level I procedures.
- Level III - Quantitative analysis of SAED patterns from a few representative fibers is added to Level II procedures.

Where asbestos is known to be present, fibers which appear to be asbestos-like by shape and by qualitative analysis of crystal structure (i.e., visual SAED) can reasonably be assumed to be asbestos. This is the case for abatement work sites in buildings with ACM. As a result, Level I analysis should be sufficient for post-abatement testing purposes. However, where definitive confirmation of airborne asbestos is needed, for legal or other purposes, a Level II or III analysis will be necessary. Thus, if only Level I analysis is employed, EM grids for all samples should be archived for future Level II or III analysis as may be needed.

3.4 ANALYSIS BY SCANNING ELECTRON MICROSCOPY (SEM)

As an electron microscopic method, SEM holds promise for greater sensitivity to thin fibers and better specificity for asbestos as compared with light microscopy. Technically, however, it currently falls short of TEM's capabilities. SEM differs from TEM in that the fiber substrate mounted on the EM grid is considerably thicker. As a result, electrons bombarding the specimen are scattered and reflected rather than being transmitted. The thick substrate also reflects and scatters electrons which are detected as "noise" by the microscope. As a result, the object being viewed must be larger than a TEM-observed object in order to be seen. In terms of fiber dimensions, the limit of resolution obtained under typical conditions is a fiber diameter of 0.20 μm .

SEM is also less powerful than TEM in its ability to distinguish asbestos from other types of fibers. SAED is not feasible with SEM due to the thick substrate and the signal noise problem noted above. Chemical analysis with EDXA is possible (for fibers with a diameter of at least 0.20 μm), but EDXA alone does not provide definitive evidence for asbestos. (Some nonasbestos fibrous materials have similar chemical compositions.) However, in a setting such as an asbestos abatement work site where airborne asbestos is likely to be present, morphological identification of asbestos-like fibers by SEM combined with detection of asbestos-like chemical compositions for a few of these fibers would be strong support for the presence of asbestos.

Without doubt, SEM can be superior to PCM for indicating the presence of airborne asbestos. In addition, the scanning feature of SEM used at a magnification of 1,000-2,000X provides a useful means of rapidly observing fields of view and locating large fibers, clusters, and bundles.

Unlike PCM and TEM, no standardized protocol for sample preparation and analysis using SEM is currently available. Although samples are usually collected on 0.4-0.8 μm pore size polycarbonate filters, cellulose ester filters have also been employed.* Likewise, most laboratories use a relatively simple protocol for sample preparation (generally, direct carbon coating of the filter), but the specific features of the protocol differ significantly among laboratories. The same is true for instrument specifications (e.g., raster scan rate, magnification, electron beam strength) and fiber identification and counting procedures.** Without standardized protocols, it is not possible to characterize analytical accuracy and reliability of SEM results. It is difficult to know how much confidence can be placed in the results of an SEM analysis until (1) a standardized protocol is developed, evaluated, and adopted, (2) NBS reference materials are made available for calibrating instruments and procedures, and (3) a laboratory evaluation program is initiated. EPA and NBS are both initiating programs which address these deficiencies.

Based on evidence presented at the NBS/EPA conference (NBS/EPA, 1984), SEM service for asbestos analysis appears to be more available than TEM but less available than PCM. In addition, both the cost and time of analysis appear to be intermediate between PCM and TEM.

* Polycarbonate filters are preferred since problems with signal noise are fewer than with cellulose ester filters.

** An example of an SEM protocol developed by Verein Deutscher Ingenieur appears in Spurny (1985).

3.5 COMPARISON OF THE THREE METHODS FOR POST-ABATEMENT TESTING

As summarized in Table 3-1, PCM, TEM, and SEM offer clear if not easy choices for measuring airborne asbestos following an abatement project. PCM is currently the most widely used technique, due to its history of use for meeting OSHA workplace exposure standards and to its availability. Since OSHA monitoring is required for many asbestos removal projects, it seems only natural to many building owners to specify a PCM-based criterion for determining project completion. Not only is PCM the most popular method, the PCM analytical protocol and the laboratories offering PCM service are the best characterized. Finally, PCM's low cost and short turnaround time make it an attractive choice when contractors are waiting to complete an abatement project. But PCM measurements are, at best, only rough indicators of asbestos contamination following abatement.

TEM is distinguished from PCM on all characteristics. It is more sensitive to thin fibers and more specific for asbestos, on the one hand, and less available, more costly, and more time consumptive on the other. With respect to method characterization and development, TEM has shown substantial improvement during the last few years. The availability of qualified laboratories offering TEM service also should improve as the demand for service increases. This should put downward pressure on future costs and turnaround times. In the short term, however, users of TEM for determining the completion of abatement projects will be faced with relatively high costs and long delays in obtaining results of analyses. Specifying EPA Level I analysis may mitigate these problems to some extent, as suggested by the low end of the cost and time estimates for TEM in Table 3-1. (A portion of the range of cost and time estimates for TEM reflects direct compared with indirect methods of sample preparation.)

SEM appears to lie between PCM and TEM on most characteristics: it is potentially more sensitive to thin fibers and more specific for asbestos than PCM but less so than TEM; it is more readily available (and popular) than TEM but less so than PCM; and estimates for both cost and time of analysis are higher than for PCM but lower than for TEM. SEM's greatest handicap is inadequate method characterization, including the lack of a standardized protocol for sample preparation and analysis. Efforts by EPA and NBS to evaluate the utility of SEM, to provide standard reference materials, and to develop a laboratory testing program should improve SEM characterization.

It is important to note that the estimates in Table 3-1 assume up-to-date instruments, skilled analysts, good operating conditions, and strict quality assurance practices. Where these assumptions do not hold, the estimates of method sensitivity and specificity may not apply. In addition, both TEM and SEM can be conducted with various degrees of sophistication. The three EPA levels of analysis reflect this for TEM, as does the range of cost and time estimates for SEM. For example, SEM could be conducted with reduced sensitivity in order to detect

TABLE 3-1. COMPARISON OF METHODS FOR MEASURING AIRBORNE ASBESTOS

	PCM	SEM	TEM
Standard Methods	NIOSH P&CAM 239 Method*	No standard method.	EPA provisional method & update**
Quality Assurance	Proficiency Analytical Testing Program; no NBS reference materials.	No lab testing, or NBS reference materials.	Limited lab testing, NBS reference materials available.
Cost	\$25-50	\$50-300	\$200-600
Availability	Most available.	Less available.	Least available.
Time Requirements	1 hr preparation & analysis, <6 hrs. turnaround	4 hr preparation & analysis, 6-24 hrs. turnaround	4-24 hr preparation & analysis, 2-7 days turnaround
Sensitivity (Thinnest Fiber Visible)	0.15 μm at best; 0.25 μm typical.	0.05 μm at best; 0.20 μm typical.	0.0002 μm at best; 0.0025 μm typical.
Specificity	Not specific for asbestos.	More specific than PCM but not definitive for asbestos (SEM with EDXA)	Definitive for asbestos (Level III -- TEM with EDXA & SAED)
Collection Filters	0.8-1.2 μm cellulose ester.	0.4-0.8 μm polycarbonate best, cellulose ester also used.	0.4 μm polycarbonate, or 0.45 μm cellulose ester if organic contaminants present.

* Leidel et al., 1979. NIOSH 7400 (NIOSH, 1984) is an alternative.

** Samudra et al., 1978; Yamate, 1984.

Source: Based on information from the EPA/NBS conference on post-abatement air monitoring (NBS/EPA, 1985), the open literature, and government reports, and on peer review comments.

PCM-equivalent fibers (i.e., fibers with diameters greater than 0.25 μm and at least 5 μm in length) and without EDXA analysis to distinguish nonasbestos fibers from those that are asbestos-like. Such an analysis may cost as little as \$50 and take only a few hours, but obviously would provide no more information than a PCM analysis. A more sophisticated SEM analysis, which counts all fibers 0.020 μm or more in diameter and which uses EDXA on some fibers, would likely approach the high end of the cost and time range (\$300) and requires more than one day for analysis.

Whichever method of measuring airborne asbestos is chosen, the exact specifications of the analysis (sensitivity, specificity, cost, and turnaround time) should be clearly communicated to the laboratory. Limits of fiber resolution should then be verified by the laboratory.

To summarize:

- (1) If PCM is selected as the method of analysis, the results should be reliable, the cost modest, and the turnaround time rapid. Strictly speaking, however, the results can only indicate success in removing large airborne fibers of both asbestos and other composition--the relationship between PCM fibers and asbestos fibers in this situation rests solely on deduction.
- (2) If TEM is selected as the method of analysis, the results should be reliable and should indicate the level of all asbestos fibers; but the cost will be high and the turnaround slow. (Remember, the specificity of a Level II or III analysis is higher than that of Level I, but cost and turnaround time are also higher.)
- (3) If SEM is selected as the method of analysis, the results should indicate the level of most airborne asbestos fibers (although some nonasbestos fibers may also be counted and the smallest fibers will not be counted), and the cost and turnaround time will be between those for PCM and TEM; but the results will not necessarily be reliable.

CHAPTER 4

AIR SAMPLING PROCEDURES

This chapter describes recommended air sampling equipment and procedures for use in post-abatement clearance monitoring. As summarized in Chapter 2, the recommended approach is "aggressive sampling." Specifications for aggressive sampling are provided, including the characteristics of forced-air equipment. The volume of sampled air needed to evaluate alternative release criteria is also discussed. The number of samplers and their location within the work site are noted here and discussed more fully in Chapter 5.

4.1 SAMPLING EQUIPMENT

In the sampling process, air is drawn through a filter at a known rate by a flow-controlled pump. The sampler components are described below.

4.1.1 Filter Media

The selection of a filter for sample collection will depend on which method is used to analyze the sample for asbestos. When PCM is employed, the filter should be cellulose ester with a pore size of 0.8-1.2 μm , as specified in the P&CAM 239 protocol (Leidel et al., 1979).^{*} When either TEM or SEM is used, the first choice in filter media is polycarbonate with a pore size of 0.4 μm . When substantial quantities of airborne organic materials are present, a 0.45 μm cellulose ester filter is recommended together with the indirect method of sample preparation for TEM (Yamate, 1984). Cellulose ester filters have also been used for SEM analysis, although they tend to cause additional background "noise" problems (see Chapter 3). Select the proper filter type and check each filter lot for low background asbestos counts prior to sampling. (See Chapter 6 for additional information on quality assurance.)

4.1.2 Filter Cassettes

Commercial filters are sold as filter and cassette combinations. If cassettes are loaded with filters outside the manufacturers' facilities, loading should take place only under clean laboratory conditions (i.e., either in a clean room or on a class 100 clean bench with a laminar-flow hood). In order to obtain a uniform distribution of collected particulates across the surface of the collecting filter, a 5.0 μm pore-size cellulose ester backing filter should be placed behind

* The new NIOSH Method 7400 prescribes the use of 25-mm diameter rather than the more common 37-mm diameter filters (NIOSH, 1984). Since the area of a 25-mm filter is 45 percent less than that of a 37-mm filter, 45 percent less air needs to be sampled to achieve the same fiber density (f/mm^2) on the filter.

the collecting filter. This is followed by the cellulose support pad and the cassette base (see Figure 4-1). The filters should be sealed evenly without wrinkles.

The movement of air through the filter may cause a significant buildup of static charge on the cassettes. The static charge, in turn, is likely to affect the distribution of fibers on the filter and may cause fibers to collect on the cassette walls rather than on the filter. To guard against static buildup, the European Reference Method for Asbestos Measurement published by the Occupational Medicine and Health Laboratory recommends that a metal cowl or electrically conductive cassette be used in conjunction with the sampling train (OMHL, 1984).

4.1.3 Flow-Controlled Pumps and Orifices

Air samples should be collected using constant flow sampling pumps. A typical pump and sampling train is shown in Figure 4.2. Critical orifices are used because they are convenient and accurate in controlling flow. However, slight changes in size and shape of the orifice due to wear or accumulation of particles will change the orifice characteristics. Therefore, orifices should be monitored before, during, and after use in sampling. Pump and filter combinations must be matched to flow rate requirements since some filters produce high back pressure which limits pump capacity. Double orifice pumps can be used for collecting samples on two types of filters simultaneously.

4.2 SAMPLING PROCEDURES

4.2.1 Checking Filter Assemblies

The cassette assembly and sampling train should be checked for leaks before use. This can be accomplished by connecting the train to a metered vacuum reservoir. The apparatus must pass a leak check of less than 4 percent of the average sampling rate at a vacuum equal to or greater than the maximum value reached during the sample run (USEPA, 1977c). Alternatively, a rotameter can be used to check for leaks (see Section 4.2.2).

4.2.2 Measuring Airflow

In most applications, a high quality rotameter with arbitrary unit graduations is sufficient to monitor the sample flow rate through the sampling apparatus. When rotameters are not used, flow measurement devices such as mass flow meters and dry gas meters may be employed. The flow measuring device should be inserted behind (downstream of) the filter and the pump assembly. All measurement equipment should be capable of ranges at least 1.5 times and readable to at least 0.01 of the desired flow rate. All flow measurement equipment should be calibrated against standards of higher accuracy before and after sampling. Specific calibration procedures for dry gas meters, mass flow meters, and rotameters are found in EPA, 1977b.

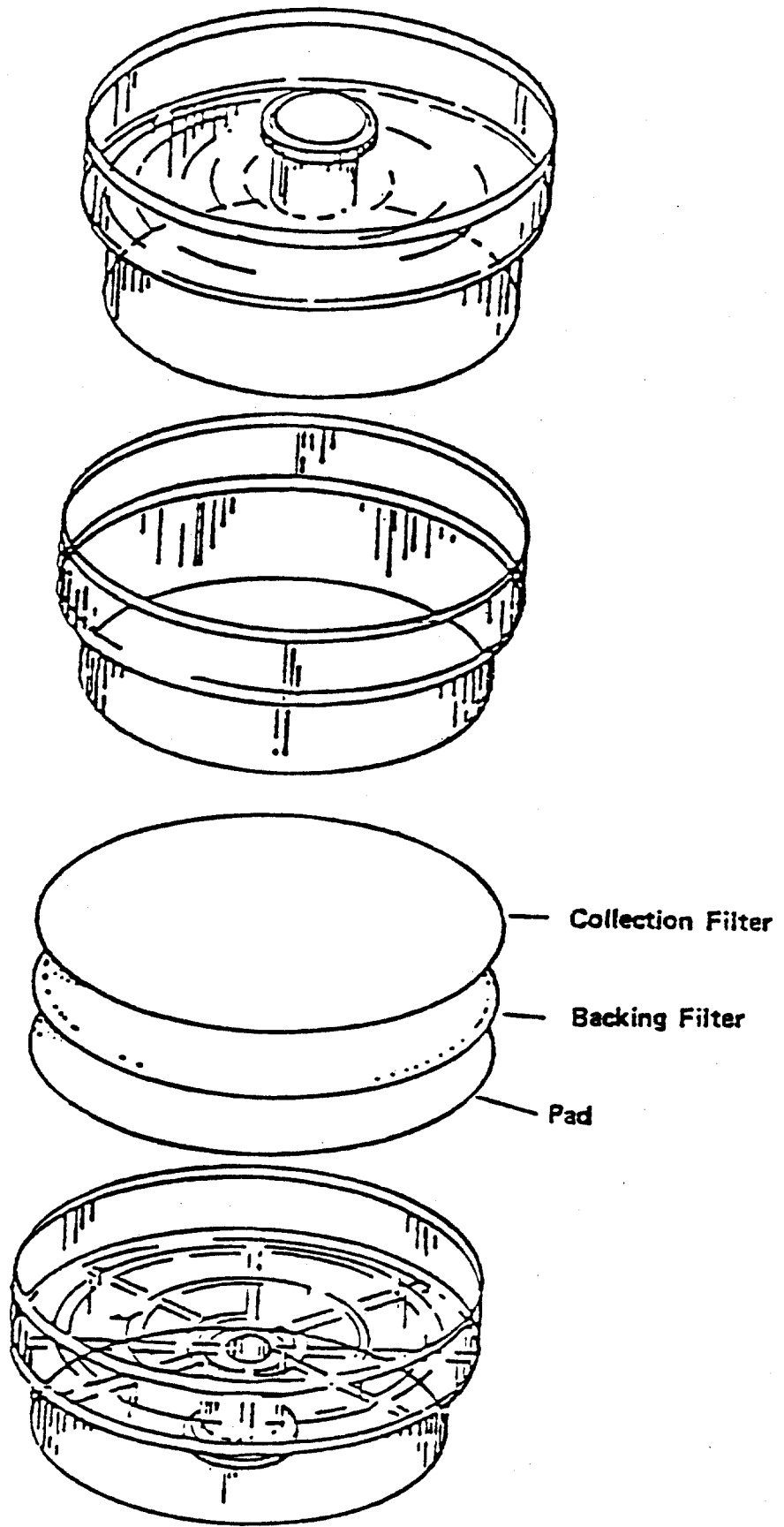

Figure 4-1. Filter and cassette assembly.

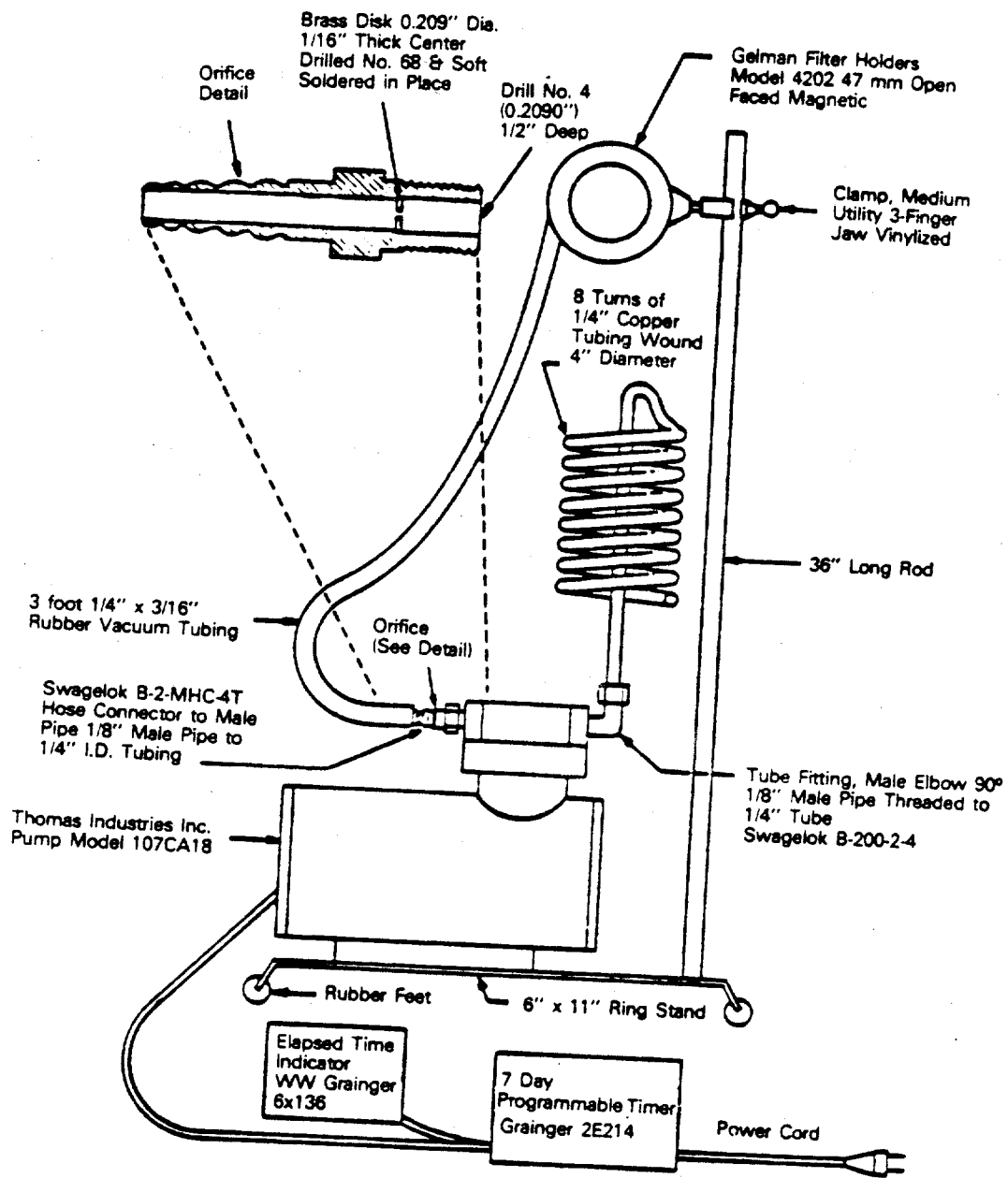

Figure 4-2. Typical pump.

4.2.3 Determining Sampling Times and Volumes

Regardless of which method is used for sample analysis, a minimum of about 3,000 liters (L) of air should be filtered at a rate of 2-12 L/min. The total sampling volume needed will depend on the criterion used to determine abatement project completion (see Chapter 5). For example, if the criterion is 0.01 PCM fibers per cubic centimeter (f/cc), then the total volume required to detect fiber levels this low is 2,850 liters:

$$V = \frac{(10 \text{ f/100 fields})}{(0.01 \text{ f/cc})} \times \frac{(855 \text{ mm}^2/\text{filter})}{(0.003 \text{ mm}^2/\text{field})} \times \frac{(1 \text{ L})}{(1000\text{cc})} = 2850 \text{ L}$$

where: (a) 10 f/100 fields is the minimum fiber loading on the filter required for reliable quantification by the P&CAM 239 Method (Leidel et al., 1979).*

(b) 0.01 f/cc is the release criterion.

(c) 855 mm²/filter and 0.003 mm²/field are, respectively, the area of a 37-mm diameter filter and the area of each viewing field. (Some optical microscopes have viewing fields as large as 0.006 mm². Larger fields of view will improve [decrease] the limit of reliable quantification for a given sampling volume.)

At 2-12 L/min, collecting 2,850 liters would require sampling for about 24 hours (2 L/min) or about 4 hours (12 L/min).

Likewise for TEM, a volume of 3,054 liters would be needed to detect asbestos levels down to, for example, 0.005 asbestos f/cc:**

$$V = \frac{(1 \text{ f/10 gd.sq.})}{(0.005 \text{ f/cc})} \times \frac{(855 \text{ mm}^2/\text{filter})}{(0.0056 \text{ mm}^2/\text{gd.sq.})} \times \frac{(1 \text{ L})}{(1000\text{cc})} = 3054 \text{ L}$$

where: (a) 1 f/10 gd.sq. is the minimum fiber loading (per 10 grid squares) for fiber detection.

(b) 0.01 f/cc is the release criterion.

(c) 855 mm²/filter and 0.0056 mm²/gd.sq. are, respectively, the area of a 37-mm filter and the area of one grid square, 75 μm on a side in a 200 mesh EM grid. (Grid squares may vary in size from 0.0056 to 0.0081 mm². Larger squares will improve [lower] the detection limit for the same sampling volume.)

These examples point out the need to estimate sampling volumes on the basis of how many fibers need to be collected for reliable measurement

* The NIOSH 7400 Method lowers the minimum fiber loading to 5 f/100 fields (NIOSH, 1984).

** If an indirect sample transfer technique is used, additional dilution terms must be added to the equation. This will increase the minimum sampling volume needed to detect one fiber.

at the air level selected as the release criterion. The number of fibers is based on the limit of reliable quantification for PCM and on the theoretical detection limit for TEM. The former is the preferred measure of the minimum required fiber loading on the filters. Unfortunately, data on which to base an estimate of the limit of reliable quantification for TEM are not available.

4.2.4 Field Operations

Samplers should be located in a room or area so that they are not unduly influenced by the configuration of the space or by each other. For example, samplers should not be placed in room corners, under shelves, or in other locations where airflow is restricted.

Once the sampling equipment is in place, the location, time, filter number, pump number, and other pertinent information are recorded. (See Chapter 6 for a detailed discussion of quality assurance requirements.) The end cap is removed from the front of the cassette and the pump is started. Normally, the cassette face is oriented in a downward position to prevent contamination of the filter by large particles falling from the ceiling. In a clean work site, however, the ceilings should be free of any large particles. Placing the filter cassette in an upward position is thus feasible. This has the added advantage of preventing the collected fibers from becoming dislodged from the filter when the vacuum is released. After the pump is started, the flow rate is recorded and verified after 15-30 minutes of operation to guard against leaks or constrictions in the sampling train. Timers are frequently used when the sampling time exceeds a few hours. When the pump needs to be shut off for any reason, the cassette should first be oriented in an upright position (if sampling has been conducted with the filter facing downward) to preclude the chance of collected fibers falling from the filter when the vacuum is released.

When the requisite sampling volume has been reached, the time, intermediate flow rate checks, and the final flow rate are recorded. Samples on cellulose ester filters are usually mailed to the laboratory for analysis without further treatment. The polycarbonate filters should be treated with special care. They should be hand carried to the laboratory if possible. To guard against fiber loss from polycarbonate filters, keep the filters in a horizontal position with the collection surface up.

4.3 SAMPLING STRATEGY

Guidelines for the number of sampling locations needed to evaluate the various release criteria are described in Chapter 5. Regardless of which criteria is selected, air sampling to evaluate compliance should be conducted "aggressively", that is, after any settled fibers have been resuspended and while fans are operated to keep them airborne.

Aggressive sampling should begin after the work site has been wet-cleaned and HEPA-vacuumed (see Chapter 2) and all plastic except the

final containment barrier removed. (That is, plastic should remain on windows, doors, and air vents.) Any negative filtration units used during abatement should remain on. The samplers are located as indicated by the sampling design. Before any sampling begins, floor, ceilings, and walls are swept with the exhaust from a high-speed air circulating device such as a 1-horsepower, electrically operated leaf blower. This activity should continue until the exhaust has been swept across all surfaces, or for at least 5 minutes per 1,000 square feet of floor area. Stationary fans (20-inch minimum in size) on 2-meter high stands are then placed at central locations so as to induce area-wide circulation. In addition, they are directed at the ceiling and operated at low speeds so as to avoid high rates of air flow in the vicinity of the sampling equipment. One fan should be used for each 10,000 cubic feet of space. The fan(s) should be left on for the duration of sampling. Aggressive sampling greatly increases the probability that fibers, if present, will be dislodged and distributed in a relatively homogeneous manner throughout the air space.

CHAPTER 5

AIR TESTING CRITERIA FOR DETERMINING WORK-SITE CLEANLINESS AFTER ABATEMENT

The overall process for determining when an abatement contractor can be released was outlined in Chapter 2 and is discussed in more detail in the updated EPA guidance document on controlling asbestos in buildings (USEPA, 1985). A two-phased approach is recommended: visual inspection followed by air testing. Air testing is designed to determine whether the work-site has been cleaned adequately. The measure of work-site cleanliness will depend on which method is chosen for measuring asbestos fibers. The recommended criteria are:

- If TEM is used, the average of measured work-site levels should be statistically no larger than the average of measured levels outside the work site.
- If PCM is used, all measured work-site levels should be no higher than 0.01 f/cc (or less, if a lower level of reliable quantification is used).

The basis for these recommendations is presented in this chapter. The discussion includes the rationale for each of the two release criteria, and the statistical basis for applying them.

Recommendations for the required sampling volumes and the number and location of air samplers follow from the choice of release criteria. As summarized in Chapter 2, sampling design recommendations are:

- If TEM is used, at least five samples inside and five samples outside each homogeneous work site should be collected. Sampling volume should be at least 3,000 liters.
- If PCM is used, at least five samples inside each homogeneous work site should be collected. Sampling volume should be at least 3,000 liters.

5.1 THE RATIONALE FOR THE RECOMMENDED RELEASE CRITERIA

The objective of measuring airborne asbestos following an abatement project is to assure that asbestos fibers released during the abatement action have been reduced to an acceptable level. Unfortunately, no safe level of exposure to asbestos exists. Any exposure to the fibers carries some risk. The point is to reduce levels to the lowest level technically possible. Hence, the lowest airborne asbestos level that can be attained within practical limitations depends upon the technological feasibility in the analytical methodologies.

Since outdoor levels are typically very low compared with levels in buildings with ACM, outdoor levels would appear to be the next best basis of comparison. However, where negative air ventilation systems are used during abatement, the make-up or "background" air comes from other parts of the building rather than directly from outdoors. In this situation, the more appropriate reference point is the level of asbestos in air outside the work site but inside the building. Thus, the recommended release criterion, if TEM is used, involves comparisons between measurements of asbestos inside the work site with those outside, either outdoors or immediately outside the work site.

The use of PCM requires additional considerations. Since PCM used according to the NIOSH protocol detects many types of fibers other than asbestos and is not sensitive enough to detect the very small fibers typical of asbestos in the ambient environment, outdoor fiber measurements using PCM provide little if any information on ambient asbestos. The same is true for airborne asbestos inside buildings other than at the abatement work site.

As an alternative to inside-outside comparisons, the recommended release criterion for use with PCM involves comparing work-site asbestos levels with the PCM limit of reliable quantification. Since the lowest level of airborne fibers quantifiable with PCM depends on the volume of air collected, the criterion could, in concept, specify any level of fibers.* A level of 0.01 f/cc is recommended as the least stringent level that should be considered.

Regardless of which method for measuring asbestos is used, the release criterion should be specified in terms of fiber rather than mass concentrations. The number of fibers rather than their mass is believed to be a better indicator of health effects (NRC, 1984). In addition, mass concentrations are unduly influenced by a few large fibers. Thus, in principle, a superficial cleaning of the work site could significantly reduce levels of asbestos mass by removing primarily a few large fibers, while leaving the concentration of total asbestos fibers almost unchanged. However, if an indirect sample preparation is used for TEM analysis in which fibers may be broken thus increasing the number of fibers in the sample, the concentration of fibers measured is likely to be higher than that in the air. Under these conditions, mass concentration is the preferred measure of asbestos levels.

* The asbestos measurement protocol for PCM specified by NIOSH (P&CAM 239) requires that at least 10 fibers be collected for 100 fields of view on the filter. This corresponds to a sample volume of about 3,000 liters (see Section 4.3.3). Thus, if a very stringent release criterion (very low concentration of asbestos) were desired, a very large sampling volume would be specified.

5.2 STATISTICAL CONSIDERATIONS FOR USING RELEASE CRITERIA

If samples of air are taken in the same general area but at slightly different locations or at different times at the same location, the measurements of sampled material will differ. Likewise, side-by-side samples taken at the same location and time will vary. Thus, measurements of airborne asbestos at an abatement worksite will be variable irrespective of abatement activities or post-abatement cleaning efforts. The task at hand is to understand this variability, and, using standard statistical procedures, to determine whether two measurements are truly different or differ only due to normal (expected) variability.

The variability of measurements of airborne asbestos has two components--sampling and analytic variability. Sampling variability is due to random fluctuations in the constituents of an air mass, and to systematic factors such as air circulation patterns in a room. Analytic variability is associated with the instruments and procedures used to sample air and analyze the samples.

Recent EPA research studies provide information on the magnitude of sampling and analytic variability for measurements of airborne asbestos using TEM (USEPA, 1983; Chesson et al., 1985a; 1985b). The results of the analyses of variability in these studies are expressed as the coefficient of variation (CV). The CV is simply the standard deviation of a series of measurements divided by the mean value.*

The first study (USEPA, 1983) produced estimates of sampling variability. A CV of 0.88 was found in simultaneous measurements of airborne asbestos among rooms with ACM in 25 school buildings within a single school district. Since the measurements of asbestos were adjusted for between-school variation in mean asbestos levels, the measurements can be considered reflective of spatial variability in a single area. Variability over time was estimated as the CV for average weekly levels of asbestos in three different schools (CV = 0.42). Spatial and time variability combined would thus be a CV of about 1.0.**

The other two studies (Chesson et al., 1985a; 1985b) estimated the analytic component of variability. Using the variation between laboratories in 49 pairs of TEM measurements of asbestos as the indicator, analytic variability was estimated as a CV of about 1.0.

Based on these limited studies, expected variability in asbestos levels at a single location (e.g., an abatement work site) as measured by TEM may be characterized by a CV of between 1.0 and 1.5.

* Since the variability of measurements of airborne asbestos tends to be larger if the average value is high, a high standard deviation may reflect a high variability and/or a high mean for the measurements. Dividing the standard deviation by the mean thus allows the variability of measurements with large means to be compared with the variability of those with small means.

** CV's are combined by taking the square root of the sum of each CV squared.

This information on the normal or expected variability of asbestos fibers is used in the following sections to calculate the required number of samples for determining compliance with the TEM release criterion. (A different approach is used for the PCM criterion.) Of course, the actual variation in asbestos levels at any site is calculated directly from the measurements at that site. The degree of expected variability is assumed solely for the purpose of determining sample design specifications before the measurements are made.

5.3 TEM RELEASE CRITERION

As noted previously, the recommended criteria for releasing the abatement contractor if TEM is used involves comparing asbestos levels at the work site with those measured outside. Only if the asbestos levels inside are not statistically larger than those outside the work site, would the contractor be released.

5.3.1 Sampling Volume and Time

The required sampling volume is determined by the lowest level of asbestos to which the work-site environment must be reduced. As shown in Table 5-1, typical ambient asbestos levels are on the order of 0.001 in rural areas and somewhat higher in urban areas. Based on these data, enough air must be sampled to detect a concentration of approximately 0.005 f/cc. As described in Chapter 4, a volume of at least 3,000 liters per sample is required if the sample preparation involves direct transfer to the EM grid, more if the indirect sample preparation technique is used. At a rate of 2-12 L/min, sampling would require from 3.5 to 21 hours.

5.3.2 The Number and Location of Samplers

The number of samples needed to reliably determine compliance with the release criterion depends on several factors. Table 5-2 lists these factors and illustrates their influence on sample size.

The first two factors are the expected errors regarding decisions on satisfactory cleaning of the abatement work site. These are the probabilities that no difference between levels inside and outside the work site will be detected when the work-site asbestos levels are actually too high (false negatives), or that a difference will be detected when the work-site levels are actually low enough (false positives).

The third factor ("inside-to-outside multiple") is related to the false positive and negative error rates. Since small differences between inside and outside asbestos levels are more difficult to detect than large differences, more samples are needed to maintain the same rates of making errors in decisions. For example, as shown in Table 5-2, if the CV for TEM is 1.5, seven samples are required to detect a 5-fold difference between inside and outside levels with a 10-percent chance of making a wrong decision. However, only four samples are required to detect a 10-fold difference. In other words, if seven

TABLE 5-1

REPORTED LEVELS OF AMBIENT ASBESTOS FIBERS MEASURED BY TEM*

Setting	Level (f/cc)	Reference
Urban	0-0.024	Murchio, 1973. "Asbestos Fibers in the Ambient Air of California," California Air Resources Board.
Rural	0-0.004	Same
Industrial	0.0002-0.011	John et al., 1976. "Experimental Determination of the Number and Size of Asbestos Fibers in Ambient Air," NTIS Report # PB-254086
Urban	0-0.045 (most below 0.01)	Chatfield, 1983. "Measurement of Asbestos Fibre Concentrations in the Ambient Atmosphere," Royal Commission on Asbestos.
Rural	0-0.003	Same

* All TEM analyses reported to have been made following direct sample preparation procedures.

TABLE 5-2

NUMBER OF SAMPLES REQUIRED TO TEST COMPLIANCE
WITH THE TEM RELEASE CRITERION

False Positive Rate	False Negative Rate	Inside-to- Outside Multiple	Number of Samples		
			CV=1.0	CV=1.5	CV=2.0
0.10	0.10	5	4	7	9
0.10	0.10	7	4	5	7
0.10	0.10	10	3	4	5
0.10	0.05	5	5	9	12
0.10	0.05	7	5	7	9
0.10	0.05	10	4	5	7

Source: Based on the method used in Breen et al., 1985 (Table 5).

samples are used, there is at most a 10-percent chance that the work site would pass the air test when levels inside were actually five times higher than outside. If the true multiple is larger than 5 and seven samples were collected, the likelihood of passing is less than 10 percent. The inside-to-outside multiple is selected when planning the air test. A multiple in the range of 5 to 10 is typically used.

The final factor is the coefficient of variation. As discussed in Section 5.3, the CV expresses the relative variation in asbestos measurements for samples at the same site. As shown in Table 5-2, the higher the CV, the larger the sample size must be.

Table 5-2 indicates that the number of required samples varies from 4 to 12. To make the task of air testing following an abatement project practical, a minimum sample size of 5 is recommended. This corresponds to false positive and negative error rates of 0.10 each, an inside-to-outside multiple of 5, and a CV of between 1.0 and 1.5.

The recommended sample size of 5 applies to samples inside as well as outside the work site. Thus, a total of at least 10 samples would be required if TEM is employed. In selecting the location of the 10 air samplers, the following guidelines should be considered:

- For indoor locations, first determine if the work site is homogeneous. "Homogeneous" refers to contiguous areas with the same type of ACM and in which one type of abatement process was performed. For example, an auditorium with accoustical ceiling plaster containing chrysotile that was removed would qualify as homogeneous. Similarly, a corridor and connecting rooms on a single floor would be homogeneous if all areas contained the same type of ACM and the same abatement method were used. Separate floors within a building and separate buildings are usually considered different work sites. Collect five samples in each homogeneous work site.
- Place the samplers within the homogeneous work site so as to collect representative samples. If the work site is a single room, disperse the samplers throughout the area. If the work site contains up to five rooms, place at least one sampler in each room. If the work site contains more than five rooms, select a representative sample of rooms. The random number procedure in Appendix A is one way to select a representative sample. Place each sampler so that it is subject to normal air circulation; avoid room corners, obstructed locations, and sites near windows, doors, or vents. Samplers placed outside the work site but within the building should be located to avoid any air that might escape through the containment barriers. Minimum recommendations are at least 50 feet from the entrance to the work site, and 25 feet from the plastic barriers.
- Outdoor samplers should be placed at ground level (about 6 feet high), if possible, and away from obstructions that may influence wind patterns. If access to electricity and concerns about security dictate a roof-top site, avoid locations near vents or other structures on the roof.

The above guidelines are designed to assure that representative samples of airborne asbestos are collected.

5.3.3 Comparing Measured Levels of Airborne Asbestos

The appropriate statistical test for comparing levels of asbestos measured at the work site with those measured outside is known as the "difference between means" using Student's "t" test:

- Compute the natural logarithm of fiber concentration for each sample.
- Compute means of the log-transformed data for inside samples and for outside samples.
- Form the ratio:

$$t = \frac{\bar{Y}_i - \bar{Y}_o}{S \sqrt{\left(\frac{1}{n_i} + \frac{1}{n_o}\right)}}$$

Where:

\bar{Y}_i = the average of log concentrations inside the work site

\bar{Y}_o = the average of log concentrations outside the work site

$S = \{[\sum(Y_{ij} - \bar{Y}_i)^2 + \sum(Y_{oj} - \bar{Y}_o)^2] / (n_i + n_o - 2)\}^{1/2}$

n_i = number of samples inside the work site

n_o = number of samples outside the work site

- Then compare t to 1.86 if 10 samples were collected (the 95 percentile point of a "t" distribution with $8 [n_i + n_o - 2]$ degrees of freedom). If t exceeds 1.86, the work site fails the test (consult a statistics text for the appropriate t value if the degrees of freedom are other than 8).

The fiber level data is log-transformed because frequency distributions of asbestos levels usually are highly skewed. The transformed data are adequately approximated by a normal distribution on which standard statistical methods can be used.

5.3.4 Recommended Actions If the Work Site Fails

For each homogeneous work site which fails the test (i.e., average asbestos levels inside the work site are statistically greater than those outside), the entire work site should be thoroughly recleaned. Wet cleaning methods should be used (see Section 2.1 and the companion EPA guidance document [EPA, 1985]). New samples (at least 5) should be

collected in the work site and analyzed for asbestos as described above. This process should be repeated until the work site passes the test. Note that for an abatement project with more than one homogeneous work site (as defined in Section 5.3.2), the release criterion should be applied to each work site independently.

5.4 PCM RELEASE CRITERION

The contractor release criterion recommended for use with PCM employs PCM's limit of reliable quantification as opposed to asbestos levels outside the work site for comparison purposes. As a result, some of the specifications for using the PCM criterion differ significantly from those for TEM.

5.4.1 Sampling Volume and Time

A minimum of 3,000 liters of air should be collected by each sampler. Since PCM can only be used as an indirect measure of asbestos, the sampling requirements should be at least as stringent as those for TEM. Based on the illustration in Chapter 4, a sampling volume of about 3000 liters will allow the PCM method to reliably quantify fibers levels as low as about 0.01 f/cc.

5.4.2 The Number and Location of Samplers

The recommended minimum number of samplers is five per homogeneous work site, or one per room, whichever is greater. Again, the rationale is that the minimum requirements for the PCM test should be at least as stringent as the TEM requirements since PCM is only an indirect indicator of asbestos. (In fact, the PCM specifications are slightly more stringent for work sites with more than five rooms.) All of the guidelines for locating samplers discussed in Section 5.3.2 (except the need for outside samplers) apply to PCM as well.

5.4.3 Comparing Measured Levels of Asbestos to the Lowest Quantifiable Level

The recommended test for the PCM release criterion is that each of the five or more samples must be less than the PCM limit of reliable quantification. If 3,000 liters is the sampling volume, this limit is approximately 0.01 f/cc. Using each sample in the test is more stringent than averaging the sample values and using the mean, as illustrated in Table 5-3. As shown, the probability that the work site would pass the test is only about 0.12 if the true asbestos levels is actually equal to 0.01 f/cc, due to variation in PCM measurements. Thus, the work site needs to be cleaned so that the actual air level is lower than 0.01 f/cc to be assured that it will pass the test.

5.4.4 Recommended Actions If the Work Site Fails

As with the TEM criterion, each homogeneous work site should be completely recleaned if it fails the test. Recleaning is followed by resampling and reanalyzing the samples.

TABLE 5-3

THE PROBABILITY OF CONTRACTOR RELEASE FOR DIFFERENT
PCM FIBER LEVELS IN THE WORK SITE*

Actual Fiber Level (f/cc)	Probability of Release
0.001	0.998
0.002	0.94
0.003	0.81
0.004	0.64
0.005	0.49
0.01	0.12
0.02	0.01
0.05	0.0003

* A negative binomial distribution and a CV of 1.0 to 1.25 are assumed for PCM fiber levels.

5.5 EXAMPLE APPLICATIONS OF THE TWO RELEASE CRITERIA

Examples of how the recommended PCM and TEM criteria for contractor release are applied will illustrate the guidelines described in this chapter and problems that may arise in certain situations. The following examples assume that 3,000 liters of air are filtered by each sampler.

5.5.1 PCM Example

Work Site: Five school classrooms, one auditorium, and one connecting corridor. Samplers are located in each area (seven samplers altogether).

Release Criterion: All measurements must be less than 0.01 f/cc.

PCM Results: <0.01, <0.01, <0.01, 0.045, <0.01, <0.01, <0.01 f/cc.

Interpretation of Results: Work site fails.

First PCM Retesting Results (after recleaning the entire work site): <0.01, <0.01, 0.012, <0.01, <0.01, <0.01, <0.01

Interpretation of Results: Work site fails.

Second Retesting Results: All seven samples, <0.01 f/cc.

Interpretation of Results: Work site passes.

In this example, all PCM samples in the first test were below the release criterion except the fourth sample, which is significantly higher (0.045 f/cc). According to the guidelines, the entire work site should be recleaned. Some may argue that only the room with the high measurement should be recleaned. However, the seven PCM measurements only represent a sample of the entire work site. Air samplers placed in other locations may also show high levels. In addition, the low sensitivity and specificity of the PCM test argues for a comprehensive response if the test fails. (Remember that a work site could pass the PCM test while failing the more sensitive and specific TEM test.) The example also shows that one sample in the first retest (the third sample this time) was still above the 0.01 f/cc criterion. The fact that the work site again failed to pass the test could reflect either inadequate cleaning and/or normal variability in PCM measurements of airborne fibers. Nevertheless, a second recleaning and retesting is recommended. Note that the five or more samplers need not be placed at the same locations for retesting.

5.5.2 TEM Example

Work Site: The entire first floor of an office building (30 offices, two rest rooms, a reception area, and a connecting corridor). The five work site air samplers are

placed in three offices, one rest room, and the corridor. The five outside samplers are placed in two stairwells between the first and second floors.

Release Criterion: The average of inside samples must be statistically no greater than the average of the outside samples.

TEM Results:

	<u>Fiber Level (f/cc)</u>	<u>Natural Log of Fiber Level</u>	<u>Mean of Logs</u>
Inside Samples	0.073	-2.62	-3.48 (\bar{Y}_i)
	0.032	-3.44	
	0.008	-4.83	
	0.057	-2.86	
	0.026	-3.65	
Outside Samples	<0.005*	-5.30	-4.51 (\bar{Y}_o)
	0.010	-4.61	
	0.024	-3.73	
	0.009	-4.71	
	0.015	-4.20	

Difference of means test:

$$s = \left\{ \frac{[\sum(Y_{ij} - \bar{Y}_i)^2 + \sum(Y_{oj} - \bar{Y}_o)^2]}{n_i + n_o - 2} \right\}^{1/2}$$

$$= \left[\frac{(2.98 + 2.26)}{8} \right]^{1/2} = 0.809$$

$$t = \frac{\bar{Y}_i - \bar{Y}_o}{s \sqrt{\left(\frac{1}{n_i} + \frac{1}{n_o}\right)}} = \frac{(-3.48) - (-4.51)}{0.809 \sqrt{\left(\frac{1}{5} + \frac{1}{5}\right)}} = 2.01$$

Interpretation of Results: Work site fails because $t > 1.86$.

TEM Retesting Results (after recleaning the entire work site):

	<u>Fiber Level (f/cc)</u>	<u>Natural Log of Fiber Level</u>	<u>Mean of Logs</u>
Inside Samples	0.081	-2.51	-4.17 (\bar{Y}_i)
	<0.005*	-5.30	
	0.011	-4.51	
	0.025	-3.69	
	0.008	-4.82	
Outside Samples	Same as before (no new sampling is needed)		

* Assumed to be 0.005 for purposes of calculation.

Difference of means test:

$$s = \left[\frac{(4.80 + 2.26)}{8} \right]^{1/2} = 0.940$$

$$t = \frac{(-4.17) - (-4.51)}{0.940 \sqrt{\left(\frac{1}{5} + \frac{1}{5}\right)}} = 0.57$$

Interpretation of Results: Work site passes because $t < 1.86$.

This example illustrates how the use of average fiber concentrations in the TEM criterion influences the results. After the initial cleaning, levels inside the work site were significantly higher than those immediately outside. Since the t-test is greater than 1.86 (2.01), the entire work site is recleaned. The second set of work-site samples reveals lower air levels with one exception--the first sample (0.081 f/cc) is higher than any of the samples in the first or second rounds of testing. However, the mean of all second round samples is lower than the mean of the first, and the contractor is released since the t-test is less than 1.86 (0.57). Some may be concerned about the single high level found during the second round of sampling, and would argue for another recleaning of the work site. Recall, however, that TEM measurements are expected to be highly variable, and that a single high value is not necessarily a cause for concern. On the other hand, a simple rule such as "if any single value is more than 'x' times the mean for all values, the work site must be recleaned" could be used as a supplement to the recommended TEM criterion. Such a rule would help guard against the possibility of a single contaminated room in an otherwise clean work site.

CHAPTER 6

QUALITY ASSURANCE PRACTICES

Regardless of which method for measuring airborne asbestos is used, reliable results can be obtained only if the collection, transfer, handling, analysis, interpretation, and documentation of the data follow specified procedures. Procedures for data collection, analysis, and interpretation were described in Chapters 3, 4, and 5; procedures for transferring and handling the data are included in this chapter. In order to insure that all of these procedures are carefully followed, a quality assurance (QA) program is essential.

Following are the key elements of a comprehensive QA program.

Training and Experience

- Everyone involved with measuring airborne asbestos should be properly trained and should understand his or her role.
- Only qualified air sampling firms and analytical laboratories should be hired. As noted previously, NIOSH's Proficiency Analytical Testing Program is a good source of information on qualifications of laboratories offering PCM services. Information should be requested from each PCM or TEM laboratory on:
 - the laboratory's quality control program.
 - the lowest fiber counts (f/cc) that are routinely reported.
 - the thinnest fibers that are routinely detected.

Quality Control Checks

- All sampling equipment should be calibrated and checked as described in Section 4.2.
- All analytical instruments should be calibrated with NBS reference materials, and checked as described in Leidel, et al., 1979, or NIOSH, 1984 (PCM), and Yamate, 1984 (TEM).
- One field blank and one laboratory blank per work site should be analyzed to check for asbestos contamination of blank filters.
- All labels on filters should be coded to avoid possible bias by laboratory analysts.

- One filter per work site should be split for duplicate analysis by a second laboratory. Where the duplicate analysis is significantly different, procedures used by either or both laboratories should be investigated until the source of the discrepancy is identified and corrected.

Data Handling Chain-of-Custody

- Responsibility for samples should be assigned to an individual at each stage of the testing process.
- Each step in the transfer of the data from field to laboratory to building owner should be recorded.

Documentation

- All testing procedures and test results should be documented.
- Unused filters and portions of filters should be saved for possible reanalysis at a later date.

REFERENCES

- Burdett, G. J., and Rood, A. P. 1983. "Membrane Filter, Direct Transfer Technique for the Analysis of Asbestos Fibers or Other Inorganic Particles by Transmission Electron Microscopy," *Environ. Sci. Technol.*, 17, 643-648.
- Chatfield, E. J. 1983. Measurement of Asbestos Fibre Concentrations in Ambient Atmospheres. Ontario, Canada: Ontario Research Foundation.
- Chesson, J., Margeson, D. P., Ogden, J., Reichenbach, N. G., Bauer, K., Constant, P. C., Bergman, F. J., Rose, D. P., Atkinson, G. R., and Lentzen, D. E. 1985a. Evaluation of Asbestos Abatement Techniques, Phase 1: Removal. Final Report. Washington, DC: Office of Toxic Substances and Environmental Monitoring Systems Laboratory, U.S. Environmental Protection Agency. Contracts 68-01-3938 and 68-02-3767.
- Chesson, J., Margeson, D. P., Ogden, J., Bauer, K., Constant, P. C., Bergman, F. J., and Rose, D. P. 1985b. Evaluation of Asbestos Abatement Techniques; Phase 2: Encapsulation. Draft Report. Washington, D.C.: Office of Toxic Substances, U.S. Environmental Protection Agency. Contracts 68-01-6721 and 68-02-3938.
- Chesson, J., Price, B. P., Stroup, C. R., and Breen, J. J., 1985. Statistical Issues in Measuring Airborne Asbestos Levels Following an Abatement Program. American Chemical Society Symposium on Environmental Applications of Chemometrics in Philadelphia in August 1984. (To appear in forthcoming proceedings volume.)
- National Research Council. 1984. Asbestiform Fibers, Non-occupational Health Risks. Washington, D.C.: National Academy Press.
- Leidel, N. A., Boyer, S. G., Zumwalde, R. D., and Busch, K. A. 1979. USPHS/NIOSH Membrane Filter Method for Evaluating Airborne Asbestos Fibers. Washington, D.C.: National Institute of Occupational Safety and Health.
- NBS/EPA. 1985. Proceedings of the Workshop on the Monitoring and Evaluation of Airborne Asbestos Levels Following an Abatement Program. Cosponsored by U.S. Environmental Protection Agency and National Bureau of Standards. Held at NBS, Gaithersburg, Maryland, March 12-13, 1984.
- NIOSH. 1984. Fibers, Method 7400. Cincinnati, Ohio: National Institute of Occupational Safety and Health.
- OMHL. 1984. MDHS 39, Methods for the Determination of Hazardous Substances, Asbestos Fibers in Air, Determination of personal exposure by the European Reference version of the membrane filter method, Health and Safety Executive. London: Occupational Medicine and Hygiene Laboratory.

- Samudra, A., Harwood, C. F., and Stockham, J. D. 1978. Electron Microscope Measurement of Airborne Asbestos Concentration: A Provisional Methodology Manual. Washington, D.C.: Office of Research and Development. U.S. Environmental Protection Agency. EPA 600/2-77-178.
- Small, J. A., Steel, E. B., and Sheridan, P. J. 1985. "Analytical Standards for the Analysis of Chrysotile Asbestos in Ambient Environments," Anal. Chem., 57, 204-208.
- Spurny, K. R. 1985. "Measurement of Asbestos and Other Mineral Fibers in Ambient and Indoor Air," Proceedings of the Workshop on the Monitoring and Evaluation of Airborne Asbestos Levels Following an Abatement Program. Cosponsored by U.S. Environmental Protection Agency and National Bureau of Standards. Held at NBS, Gaithersburg, Maryland, March 12-13, 1984.
- Steel, E. B., and Small, J. A. 1985. "Accuracy of Transmission Electron Microscopy for the Analysis of Asbestos in Ambient Environments," Anal. Chem., 57, 209-213.
- USEPA. 1977a. Montgomery County Asbestos Study. RTP, N.C.: Office of Research and Development, USEPA.
- USEPA. 1977b. Quality Assurance Handbook for Air Pollution Measurement Systems, Vol. II: Ambient Air Specific Methods. Washington, D.C.: Office of Research and Development, USEPA. EPA-600/4-77-027a.
- USEPA. 1977c. "Method 5: Determination of Particulate Emissions From Stationary Sources," Federal Register, Vol. 42, No. 160, pp. 41776-41781. (40 CFR 60, Appendix A, Method 5.)
- USEPA. 1983. Airborne Asbestos Levels in Schools. Washington, D.C.: Office of Toxic Substances, USEPA. EPA 560/5-83-003
- USEPA. 1984a Evaluation of the EPA Asbestos-in-Schools Identification and Notification Rule. Washington, D.C.: Office of Toxic Substances, USEPA. EPA 560/5-84-005.
- USEPA. 1984b. Asbestos in Buildings: National Survey of Asbestos-Containing Friable Materials. Washington, D.C.: Office of Toxic Substances, USEPA. EPA 560/5-84-006.
- USEPA. 1985. Guidance for Controlling Asbestos-Containing Materials in Buildings, 1985 Edition. Washington, D.C.: Office of Toxic Substances, USEPA. EPA 560/5-85-024.
- Yamate, G., Agarwal, S. C., and Gibbons, R. D. 1984. Methodology for the Measurement of Airborne Asbestos by Electron Microscopy. Draft Report. Washington, D.C.: Office of Research and Development, U.S. Environmental Protection Agency. Contract 68-02-3266.

APPENDIX A

A RANDOM NUMBER PROCEDURE FOR SELECTING A REPRESENTATIVE WORK-SITE SAMPLE

A table of random numbers can be used to pick a sample of rooms for air testing as follows. (A table of random numbers is simply many sequences of single-digit numbers presented in a random order.)

- (1) If the number of rooms is less than 10, each room is assigned a unique single-digit number. Rooms with numbers corresponding to the first five numbers in a selected random number sequence in the table constitute the air test sample.
- (2) If the number of rooms is greater or equal to ten (but less than 100), each room is assigned a unique two-digit number. The random number table is then considered sequences of two-digit numbers. The first five room numbers to appear in a selected sequence constitutes the air test sample.
- (3) Similarly, if the number of rooms is greater than or equal to 100, each room is assigned a unique three-digit number and the random number table is considered sequences of three-digit numbers.

Tables of random numbers can be found in any statistics textbook, such as: Snedecor, G. W., and Cochran, W. G., 1976. *Statistical Methods* (6th Ed.). Iowa State U. Press, Ames Iowa. 593 pp.

TECHNICAL REPORT DATA
(Please read instructions on the reverse before completing)

1. REPORT NO. EPA 600/4-85-049		2.		3. RECIPIENT'S ACCESSION NO.	
4. TITLE AND SUBTITLE Measuring Airborne Asbestos Following an Abatement Action				5. REPORT DATE November 1985	
7. AUTHOR(S) D.L. Keyes, J.J. Breen, and M.E. Beard				6. PERFORMING ORGANIZATION CODE	
9. PERFORMING ORGANIZATION NAME AND ADDRESS Environmental Sciences, 6845 North Cocopas Road Tucson, Arizona, 85718, under contract to the Research Triangle Institute, P.O. Box 12194, Research Triangle Park, N.C. 27709				8. PERFORMING ORGANIZATION REPORT NO.	
12. SPONSORING AGENCY NAME AND ADDRESS Environmental Protection Agency Office of Research and Development Environmental Monitoring Systems Laboratory Research Triangle Park, N.C. 27711				10. PROGRAM ELEMENT NO.	
				11. CONTRACT/GRANT NO. 68-02-3767	
				13. TYPE OF REPORT AND PERIOD COVERED	
15. SUPPLEMENTARY NOTES				14. SPONSORING AGENCY CODE	
16. ABSTRACT <p>One of the most critical points in an asbestos abatement project is knowing when the work has been completed, the contractor can be released, and the building can be reoccupied. This decision should be based on two factors: (1) satisfactory performance of the abatement work, and (2) thorough cleaning of the work site. As outlined herein, these factors should be evaluated by virtually inspecting the work site and by measuring the level of airborne asbestos there. The evaluation should be conducted by the asbestos program manager or the technical advisor assigned to monitor the abatement work.</p> <p>This report discusses various technical issues regarding the air test. Specifications are provided for air sampling and detailed guidelines are presented for using either TEM or PCM to analyze the samples. The information is designed for asbestos program managers and technical program advisors.</p>					
17. KEY WORDS AND DOCUMENT ANALYSIS					
a. DESCRIPTORS		b. IDENTIFIERS/OPEN ENDED TERMS		c. COSAT: Field Group	
Airborne Asbestos Asbestos Abatement Asbestos-Containing Materials Asbestos Control Program Asbestos Exposure					
18. DISTRIBUTION STATEMENT		19 SECURITY CLASS (This Report)		21 NO OF PAGES	
		20 SECURITY CLASS (This page)		22 PRICE	